



Model No. LFW123FTC

Extra large security digital combination safe



Best Used For:



Fire



Flood



Jewels

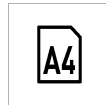

A4 Paper Documents



Storage Devices,
USB Flash Drives



Small Electronics

Overview & Features

Product Features

- Steel construction with fire and water protection
- 4 large, live locking bolts of 2,5cm diameter and pry resistant hinge bar for a higher level of resistance
- UL/ETL verified 60 minutes fire protection for documents, official papers, as well as digital items (CD, USB sticks) up to 927°C
- ETL verified water protection up to 20cm for 24 hours to protect documents and other valuable items from flood damage
- ETL verified to withstand a 4,5-meter drop during a fire and stay closed
- Programmable digital combination with backlit keypad for an easy use even in dark places: 2 resettable combinations + 1 Master combination (non programmable)
- Interior light, multi-position tray and built-in storage on the door
- Bolt down hardware included

Certifications



Product Details

The Master Lock No. LFW123FTC Extra Large Security Digital Combination Safe is designed to protect documents, digital media and other valuables from fire, water, and theft. 60% bigger bolts than traditional safes and pry-resistant hinge bar provide additional security against unauthorized access.



Product Specifications

Product Number	LFW123FTC
Description	Retail Boxed Packaging
Master Carton Qty	1
Exterior dimensions (H x W x D)	45,3cm x 41,5cm x 49,1cm
Interior dimensions (H x W x D)	34,9cm x 31,9cm x 30,2cm
Interior Volume	33,6L
Weight W/o Packaging	38,9kg
Colour	Black
Batteries	Requires 4 AAA batteries (not included)

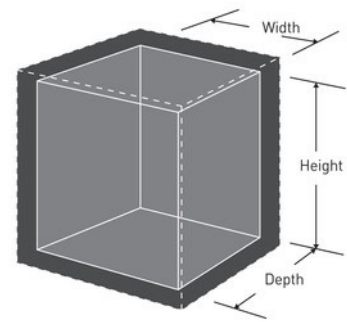

Master Lock Europe S.A.S.

131, avenue Charles de Gaulle - 92200 Neuilly sur Seine - France
O:+33-1-41437200 | F:+33-1-41437204
www.masterlock.eu